



LITERATURE

POLARIZATION CELL REPLACEMENT (PCR)



INTRODUCTION

The Polarization Cell Replacement (PCR) is a solid-state device commonly used in conjunction with cathodically protected structures to isolate cathodic protection systems while also providing continuity to ground. The PCR was introduced in 1994 as an ideal replacement for electrochemical polarization cells because the solid-state design of the PCR eliminates the maintenance requirements and the potentially hazardous electrolytes associated with polarization cells. The device's extensive third party certifications and listings ensure the product's robust design and performance to our stated ratings. These items, along with other benefits found in its operating parameters have made the PCR one of the most commonly used decouplers in the world.

PCR devices perform the necessary function of preventing the flow of DC current, while simultaneously providing a grounding (or coupling) path for steady-state AC current, fault current and lightning. PCR devices have been used in a variety of applications including AC Voltage Mitigation, Electric Equipment Decoupling, Decoupling from Utility grounding systems and more.

The PCR is rated for Class I, Division II hazardous locations. The PCR is also available in a Class I, Division I package, suitable for hazardous locations where explosive gases are commonly present. For more information, please view the PCRH.

COMMON APPLICATIONS

AC Voltage Mitigation

As an AC mitigation device, the PCR can collapse the steady-state voltage between the connected points to a negligible level by providing continuous AC grounding for pipelines with induced AC while leaving cathodic protection unaffected.

Decoupling Electric Equipment Grounding Systems

When electrical equipment is mounted on a cathodically protected structure, the PCR can provide DC isolation with fault rated AC continuity. As grounding codes apply, the PCR is listed by UL for meeting the requirements of an effective AC grounding path per U.S. and Canadian electric codes.

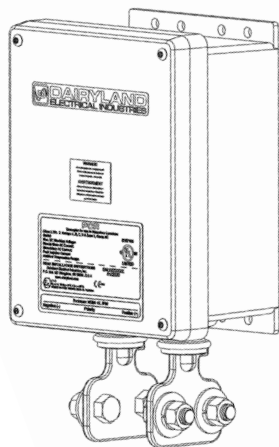

PCR

Polarization Cell Replacement

Isolated Joint Protection

Isolated joints often need over-voltage protection against lightning and AC fault current, and in some cases, steady-state induced AC voltage. Due to the small clearance between opposite sides of the isolated flange, a protective device must provide a low clamping voltage, including the voltage effects of the conductors or bus bars used to connect the product

Decoupling from Utility Grounding Systems

When a cathodically protected structure is tied into the site grounding grid, CP values may be unacceptably low, due to the bond between the site grounding system and the power company grounding system. The PCR can be installed by the power company at the transformer, to provide DC isolation and AC grounding between the two systems. This minimizes the CP current requirements and allows acceptable CP voltage for protection.

DID YOU KNOW?

The PCR has been certified by independent laboratories Underwriters Laboratories and DEMKO for compliance to worldwide standards and codes, and is certified for use in Div 2 and Zone 2 hazardous locations. For more information on certifications and listings, visit www.dairyland.com.





ELECTRICAL RATINGS

AC Fault Current Ratings

Some applications may have conditions where an over-voltage device such as the PCR is subject to fault current. For this reason, the PCR was designed to have AC fault current carrying capability. The PCR will limit the voltage between its connection points to less than 10 volts AC under the maximum fault current ratings listed below.

Four different fault current ratings are offered at 60Hz and 50Hz with the following current-time relationship:

AC Fault Current Ratings (Amps AC-RMS Symmetrical 50/60Hz)				
Hz Cycles	3.7kA	5kA	10kA	15kA
1	6500	8800	20000	35000
3	5000	6800	15000	27000
10	4200	5700	12000	21000
30	3700	5000	10000	15000

Note: Select a PCR fault current rating that encompasses the fault current available. For more information on sizing for available fault current, view our web article: [Determining AC Fault Current](#).

Steady-State AC Current Ratings

This rating represents the maximum steady-state AC current that is allowed to flow through the device while still blocking the flow of DC current. Two ratings are available for the PCR.

The table represents maximum values. As the DC voltage approaches the maximum blocking voltage rating selected, the allowable steady-state AC current is reduced as shown in Figures 1 and 2.

Steady-State Current Ratings (Amps AC-RMS Symmetrical) 50/60 Hz Ratings		
Ambient Temp	Standard 45A Rating	Optional 80A Rating
20°C	50A	90A
65°C	40A	70A

There are a number of applications where a PCR may be required to block DC while simultaneously carrying steady-state AC current. For example, when a pipeline is in the same corridor as an electrical transmission line, steady-state AC voltage is often induced on the pipeline. The PCR can mitigate this voltage by providing a low AC impedance path for AC current to flow to ground while simultaneously preventing the flow of DC current.

The steady-state AC impedance of the PCR at 60 Hz is 9.8 milliohms for the standard 45 ampere rating and 4.9 milliohms for the optional 80 ampere rating. At 50 Hz, the comparable impedances are 11.9 milliohms for the standard 45 ampere rating and 5.8 milliohms for the optional 80 ampere rating. Under an AC fault or lightning current condition, these impedances momentarily become virtually zero. For more information on steady-state current view our web article: [Measuring Steady-State AC Current](#)

DC Blocking Voltage Rating

The standard, and most commonly specified, PCR model has an asymmetrical voltage blocking rating of -3.0 volts to +1.0 volt. Either model can also be furnished with a symmetrical voltage blocking rating of +/- 2.0 volts. Optional ratings of -4V/+1V and -6V/+1V are available only with the associated AC fault current ratings of 3.7kA and 5kA.

The reasons for symmetrical and asymmetrical choices are best described with an example. If the PCR is used to provide over-voltage protection for an isolated joint and both sides of the joint are cathodically protected, the DC voltage across the joint will be the difference in voltage between the two cathodic protection systems, normally near zero volts. For this application it is desirable to select the symmetrical +/- 2.0 volt blocking rating. In the event that the cathodic protection system is OFF on one side of the joint, the device can block 2.0 VDC in either direction.

If one side of the isolated joint is cathodically protected and the other side is grounded, then it is preferable to select the asymmetrical version which blocks from -3.0 volts to +1.0 volt since one side has been shifted to a more negative voltage. Whenever one side is referenced to ground, the asymmetrical version is suggested because the CP voltage is situated in the center of the threshold voltage range.

Impulse Current Withstand Rating

All models have the same lightning impulse current rating which is shown in the following table.

Impulse Current Withstand Rating All PCR Models
Peak Amperes: 100,000
Note: 8x20 microsecond waveform



WARNING

Keep the Conductors Short!

The PCR is designed to keep the voltage between the device terminals to a limited value. During lightning conditions, a more important factor than the PCR voltage clamping capability is the voltage developed in the conductors or bus used to attach the device. Use low inductance bus bars or conductors ideally less than 6 inches (150 mm) long for best results. More information on conductor length is available at www.dairyland.com.

Ordering Instructions

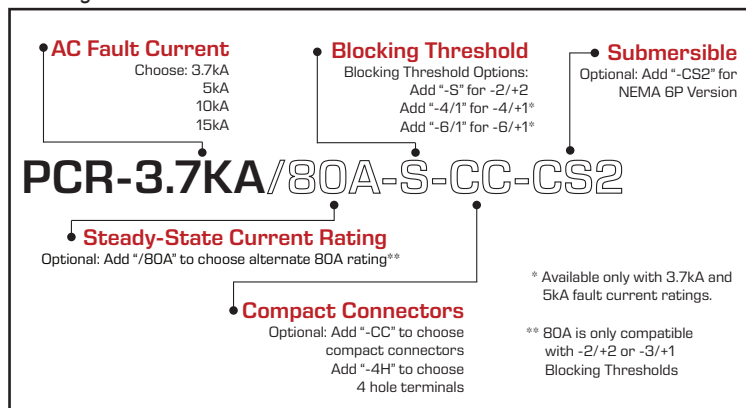

FEATURES AND CERTIFICATIONS

Certifications

The PCR has been tested by Nationally Recognized Testing Laboratories (NRTLs) for compliance to independent standards in its operation, ratings, and construction. This includes compliance to standards for:

Class I, Div. 2, Groups A, B, C, D and Zone 2, Group IIC

Class & Division System:

UL (United States) and C-UL (Canada)

- Effective Ground Fault Current Path per:
 - NFPA 70 (US National Electric Code – NEC): Article 250.4(A)(5)
 - CSA C22.1 (Canadian Electric Code, Part I): 10-002
- Isolation of Objectionable DC Ground Currents per:
 - NFPA 70: Article 250.6(E)
 - CSA C22.1: 10-100 & 10-500
- Hazardous Location Use:
Class I, Division 1 & 2, Groups B,C,D by UL & C-UL per:
 - UL 121201, 9th Ed. and CSA C22.2 No.213-17

- Safety Requirements for Electrical Equipment per:
 - UL 61010-1, 3rd Ed. & CSA C22.2 No. 61010-1
 - Overvoltage Protection from Impulse (Lightning) Current:
100kA (8 x 20µs)
 - Enclosure Rating: NEMA 4X (NEMA 6P Optional)
 - Temperature Range: -45°C to +65°C (-49°F to +149°F)

Zone System: ATEX / IECEx / UKEx (Europe / International / UK). ATEX per directive 2014/34/EU (Equipment for use in Potentially Explosive Atmospheres):

- Zone 2, Group IIC, Increased Safety "ec"
- EN IEC 60079-0: 2018
- EN IEC 60079-7: 2015+A1:2018
- IEC 60079-0: 2017
- IEC 60079-7: 2017
- Overvoltage Protection from Impulse (Lightning) Current:
100kA (8 x 20µs)
- Temperature Range: -45°C to +65°C
- Enclosure Rating: IP66

Solid-State Design

The PCR is built with proven solid-state components which have an instantaneous response with respect to voltage, thereby initiating voltage clamping immediately when the voltage attempts to exceed the blocking level selected.

Fail-Safe

An important safety feature for the PCR is that if subject to AC fault current or lightning impulse current in excess of rating such that failure occurs, failure will occur in the shorted mode. In the shorted mode, the unit can carry greater than rated fault current or lightning impulse current and still provide an effective grounding (or conducting) path.

Enclosure

The PCR enclosure is made of a light gray fiberglass-reinforced polyester material suitable for outdoor non-submersible applications and is rated NEMA 4X (comparable to IP 66). Optionally, the PCR can be supplied as a submersible device with the same dimensions rated NEMA 6P (comparable to IP68). The optional submersible version of the PCR must not be installed such that it may be submerged in freezing conditions.



Terminals

Two-hole spade terminals are standard, but compact connectors and 4 hole NEMA terminals are available. Compact connectors are recommended where necessary to insulate the connections to the PCR after installation (for example, with a user furnished heat-shrink sleeve). Add “CC” to the end of any model number only if compact connectors are required, or “4H” for 4 hole terminals.

PCR terminals have preinstalled 1/2” stainless hardware (bolts, nuts, washers).

Examples:

PCR-10KA (Standard connector)

PCR-10KA-CC (Compact connector)

PCR-15KA-4H (4 hole terminal)

Polarity / Electrical Connection

Polarity marks (+) and (-) are provided near the terminals to aid in proper installation. Connect the (-) to the structure with CP or more negative structure and the (+) to the grounded, or more positive, system.

Size and Weight

Refer to outline drawings for dimensional data. Packaged weight varies from approximately 12-22 pounds (5.5-10kg) depending on model selected.

Number of Operations

Virtually unlimited under maximum ratings, provided the operations are not immediately repetitive.

Energy Requirements

None. The devices are totally passive.

MOUNTING OPTIONS

The PCR is made to mount on a flat surface (e.g., a wood post, unistrut, panel) with two 3/8” (≈10mm) diameter bolts furnished by user; however, a number of optional mounting methods and accessories are available for specific applications.

Mounting Accessories

Numerous mounting accessories are available from Dairyland to aid in the proper installation of the PCR. Detailed accessory information, including complete installation instructions are available on Dairyland.com.

Specific Installation Guidance

The Dairyland website contains detailed information on the installation methods specific to a given application. For wiring diagrams and/or application guidance, see Dairyland.com.

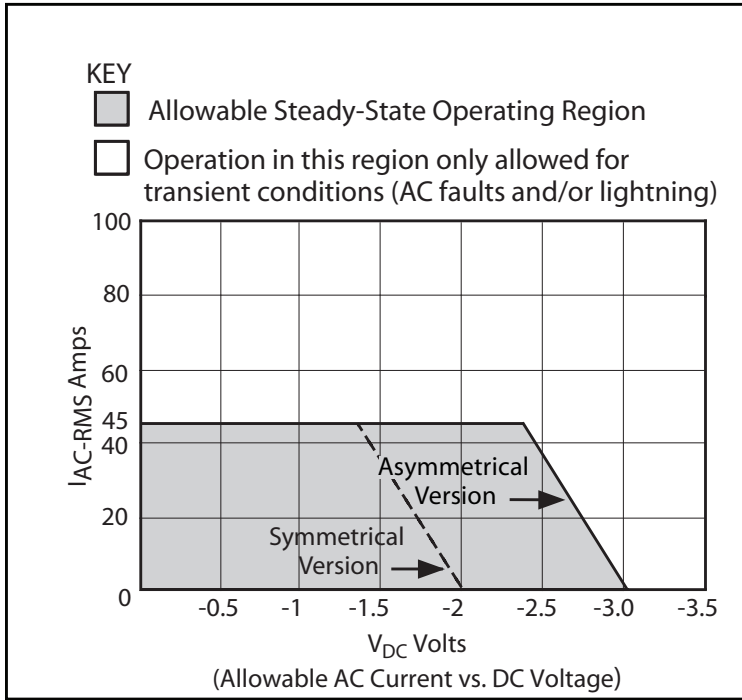

FIGURE 1: PCR Operating Characteristics @ 43°C
(Standard 45A @ 50/60 Hz)

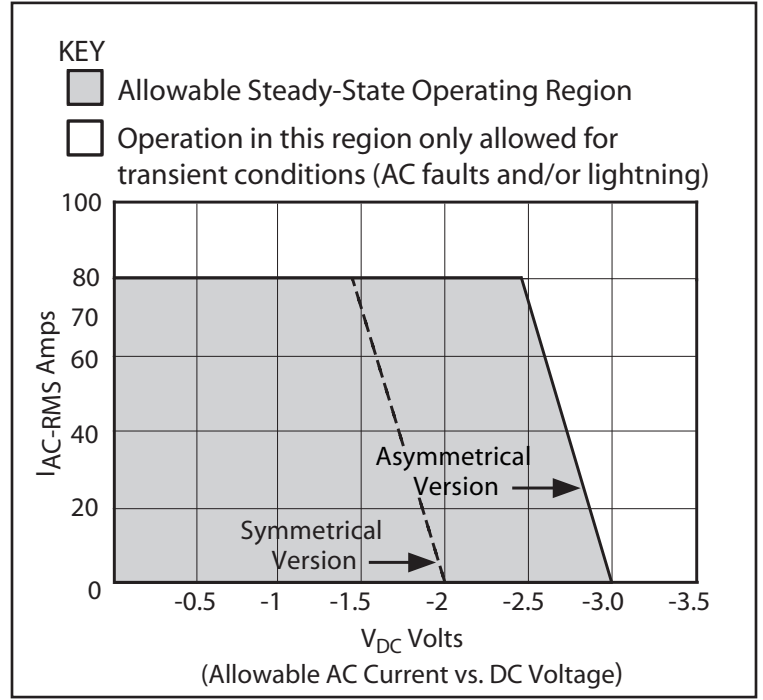

FIGURE 2: PCR Operating Characteristics @ 43°C
(Standard 80A @ 50/60 Hz)

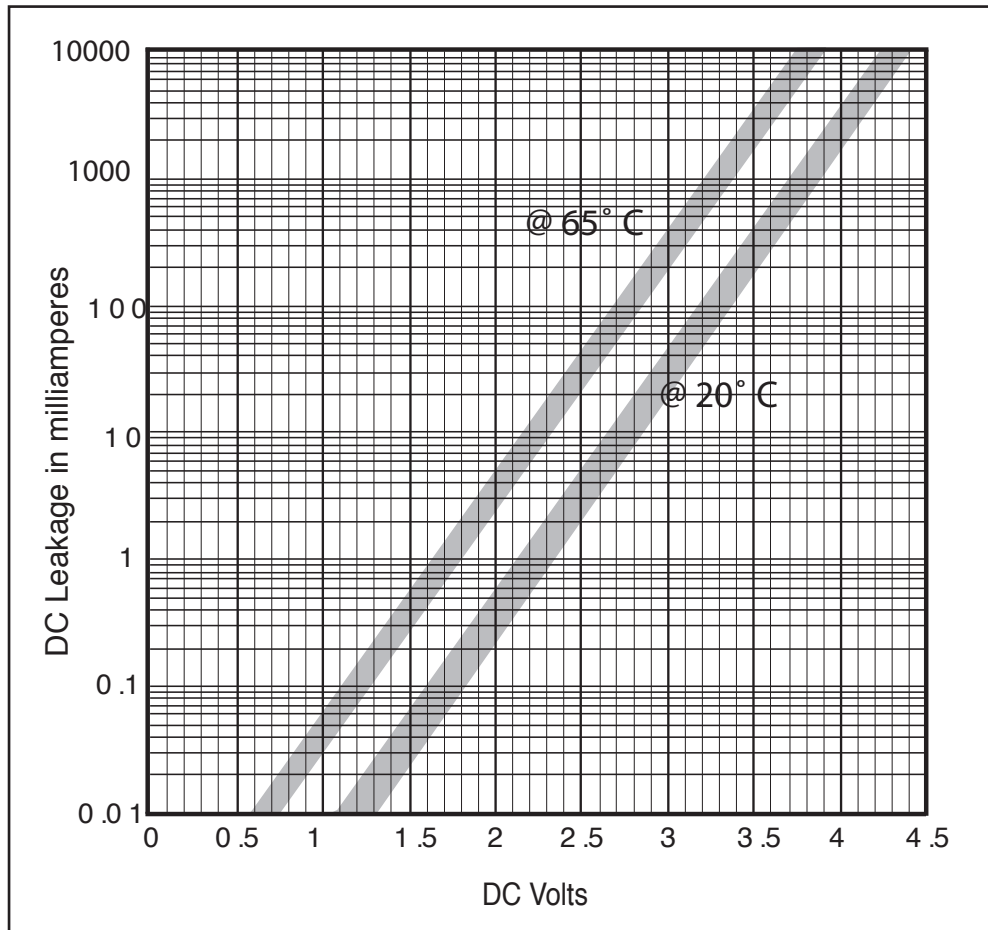
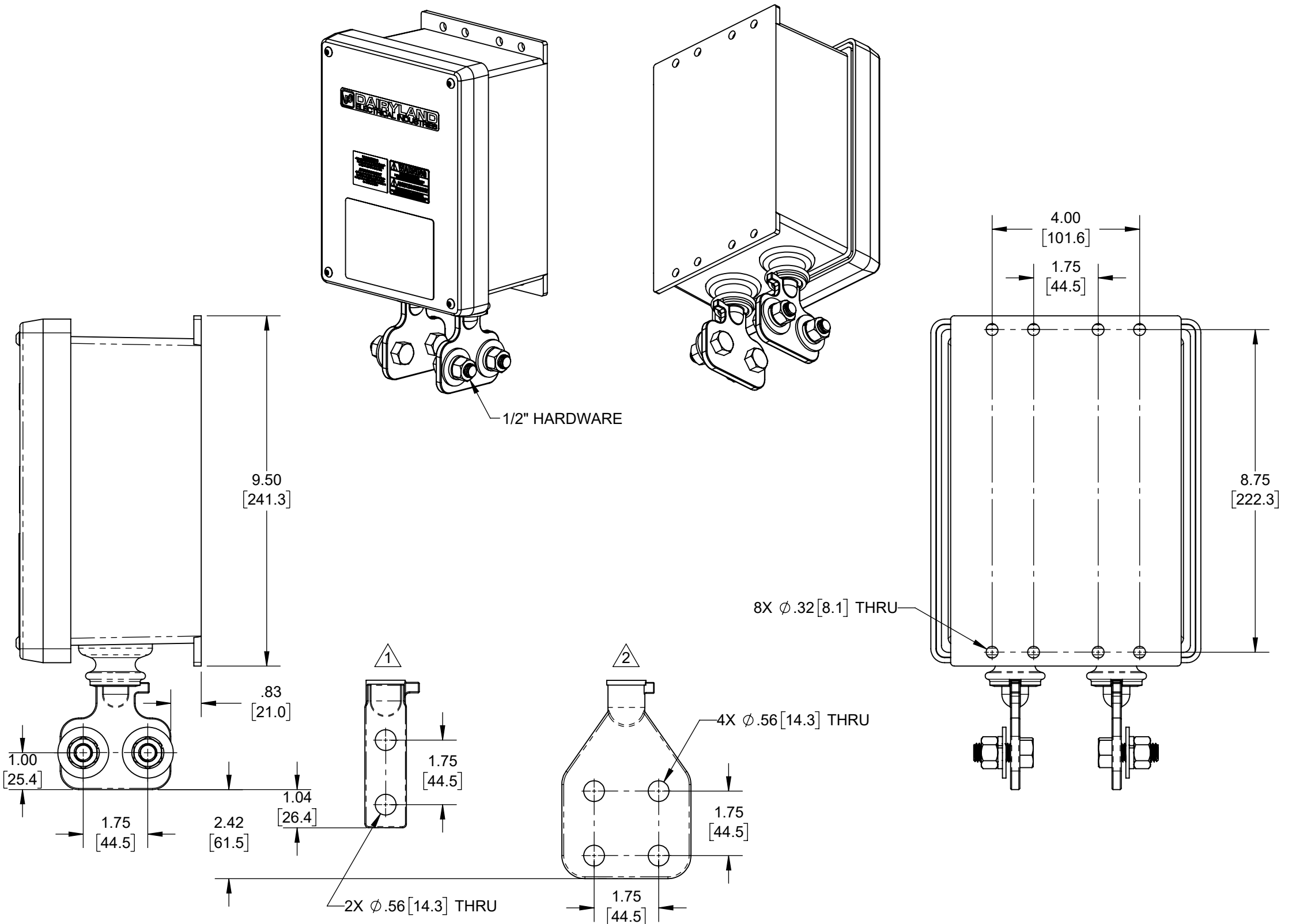
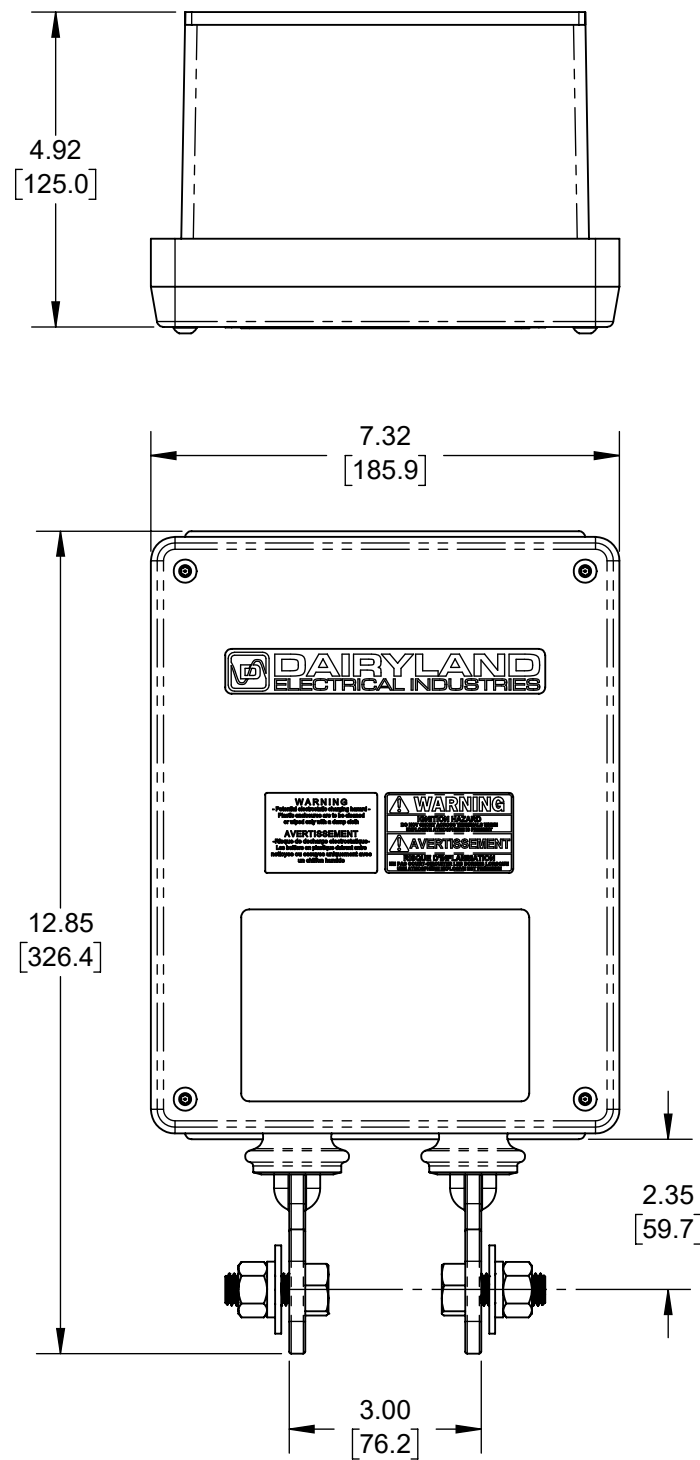
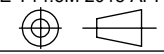

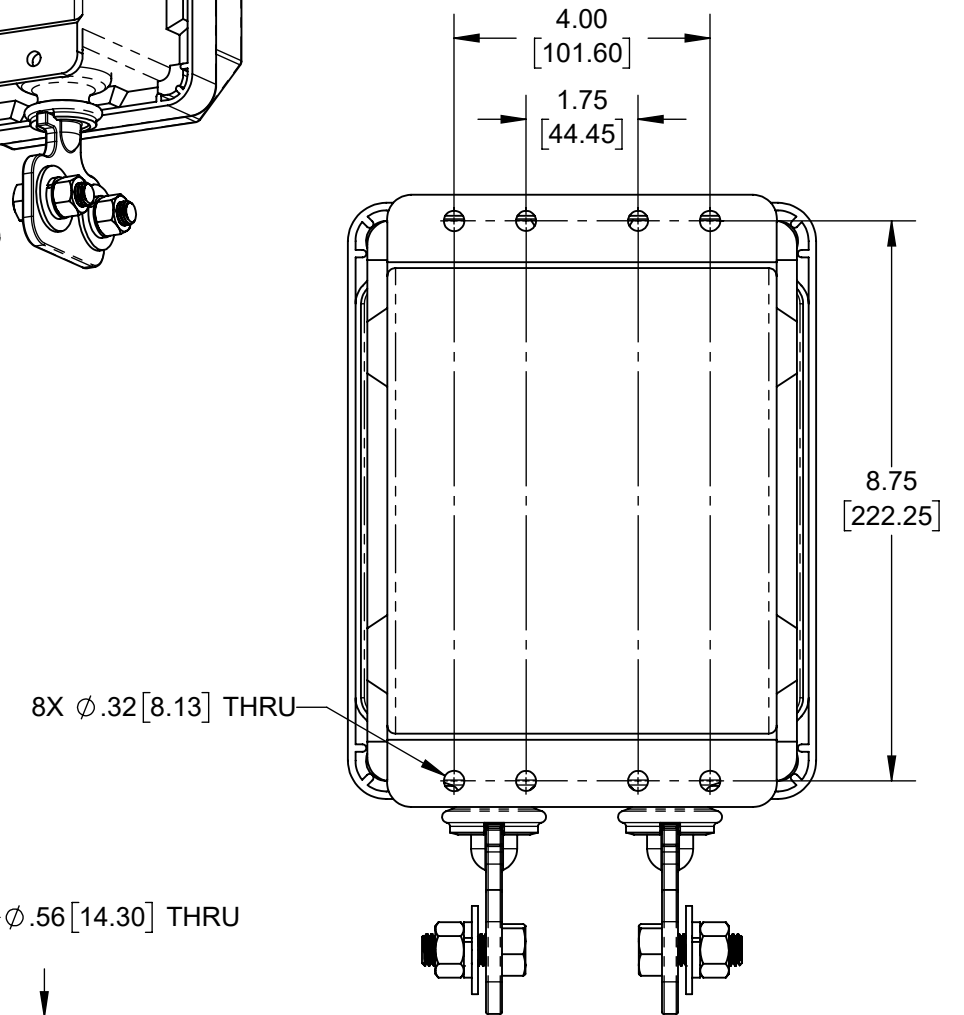
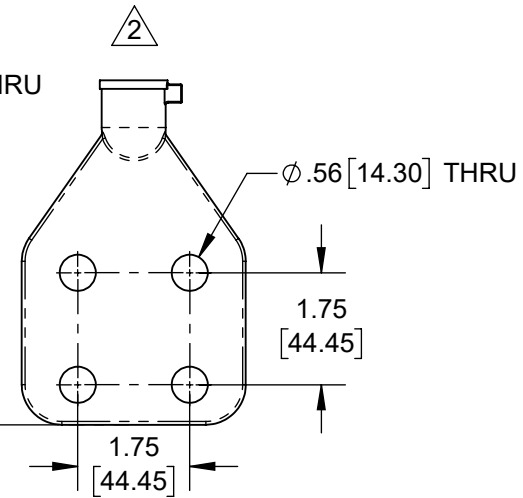
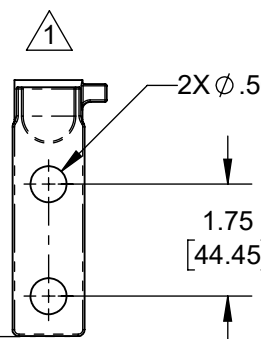
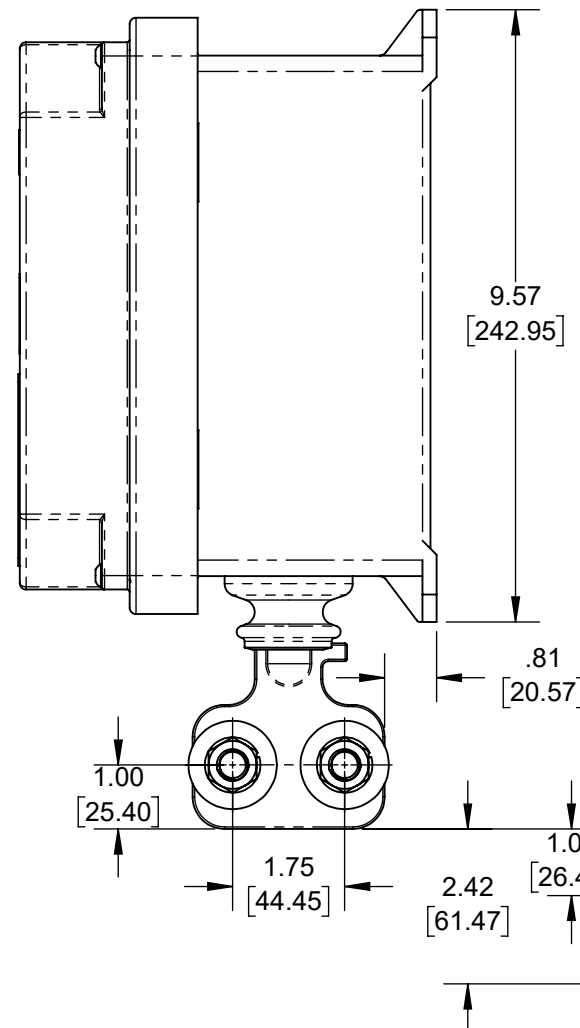
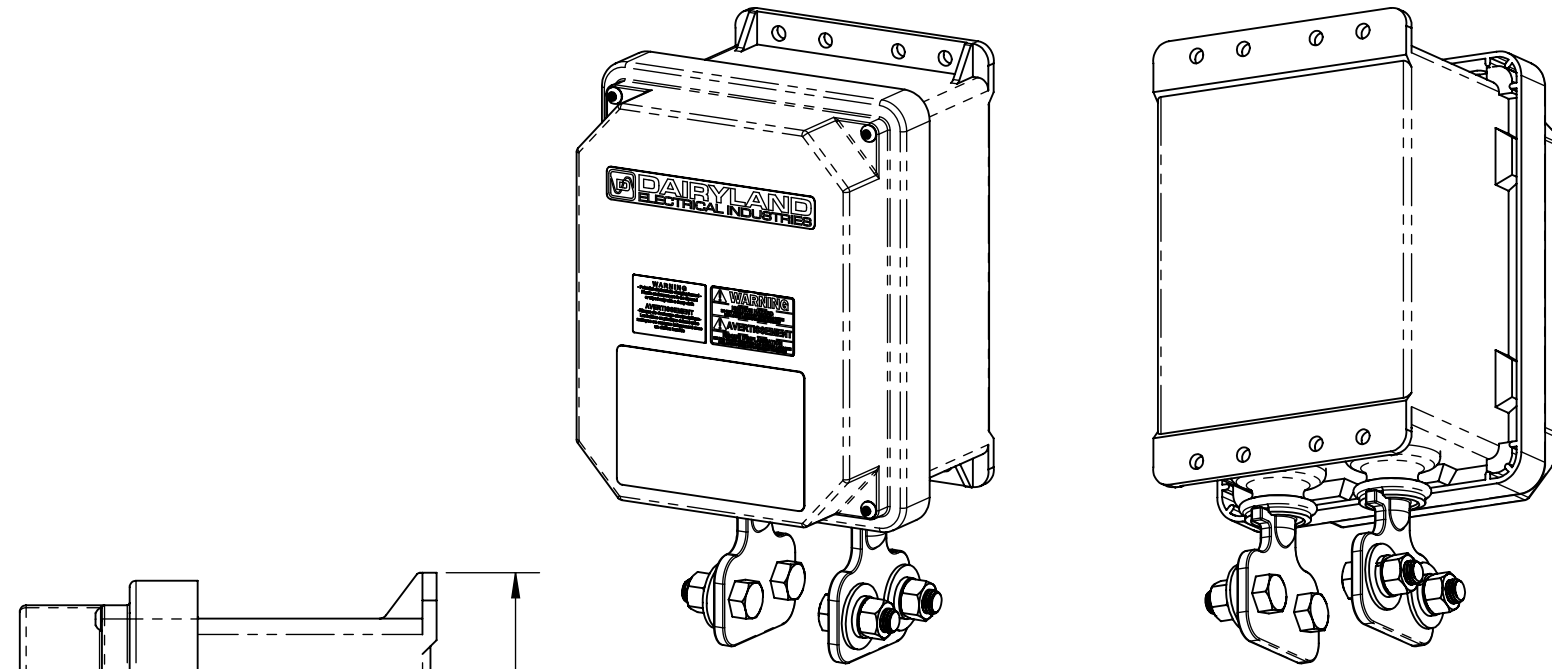
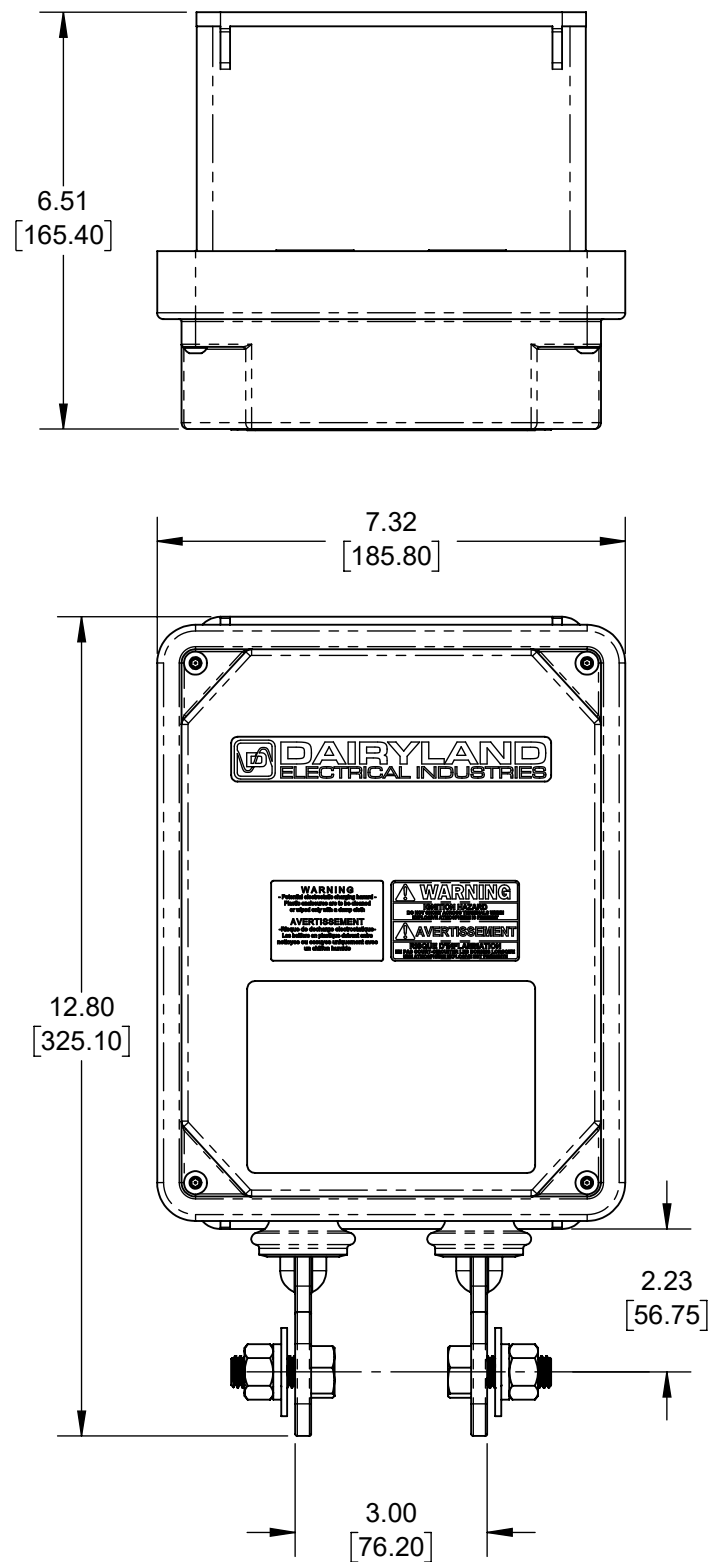

FIGURE 3: DC Voltage vs. DC Leakage Current
(Standard Asymmetrical PCR with -3V / +1V Blocking Voltage)





- NOTES:
- ① ALTERNATE TERMINAL: SPECIFIED BY ADDING "-CC" TO ANY PCR MODEL NUMBER
 - ② ALTERNATE TERMINAL: SPECIFIED BY ADDING "-4H" TO ANY PCR MODEL NUMBER

ASME Y14.5M 2018 APPLIES  UNLESS OTHERWISE SPECIFIED DIMENSIONS ARE IN INCHES. COMPUTER-GENERATED DRAWING DO NOT EDIT MANUALLY.	MATERIAL:	DRAWN: JPW	DATE DRAWN: 2014-06-20	 DAIRYLAND ELECTRICAL INDUSTRIES, INC. P.O. BOX 187 STOUGHTON, WI 53589 608-877-9900 DAIRYLAND.COM
	FINISH: NA	DWG APPROVAL: JSJ	DATE APPROVAL: 07/15/2025	
.XXX = ±.005" .XX = ±.01" .X = ±.03" ANGLES = ±1°	TITLE: PCR 3.5kA THRU 10kA OUTLINE DRAWING		SHEET: OF DWG SIZE: SCALE: REV: PART #: 1 1 B 1:3 C 100060	
<small>THE INFORMATION CONTAINED IN THIS DRAWING IS THE SOLE PROPERTY OF DAIRYLAND ELECTRICAL INDUSTRIES, INC. ANY REPRODUCTION IN PART OR WHOLE, WITHOUT THE WRITTEN PERMISSION OF DAIRYLAND ELECTRICAL INDUSTRIES, INC. IS PROHIBITED.</small>				



NOTES:

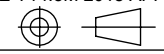

- ① ALTERNATE TERMINAL: SPECIFIED BY ADDING "-CC" TO ANY PCR MODEL NUMBER
- ② ALTERNATE TERMINAL: SPECIFIED BY ADDING "-4H" TO ANY PCR MODEL NUMBER

ASME Y14.5M 2018 APPLIES  UNLESS OTHERWISE SPECIFIED DIMENSIONS ARE IN INCHES. COMPUTER-GENERATED DRAWING DO NOT EDIT MANUALLY.	MATERIAL:	DRAWN: JPW	DATE DRAWN: 2015-05-29	 DAIRYLAND ELECTRICAL INDUSTRIES, INC. P.O. BOX 187 STOUGHTON, WI 53589 608-877-9900 DAIRYLAND.COM	
	FINISH: NA	DWG APPROVAL: JSJ	DATE APPROVAL: 07/15/2025		
.XXX = \pm .005" .XX = \pm .01" .X = \pm .03" ANGLES = \pm 1°	TITLE: PCR 3.5KA THRU 10KA 80A OUTLINE DRAWING		SHEET: OF 1 1	DWG SIZE: SCALE: REV: B 1:3 C	PART #: 100081

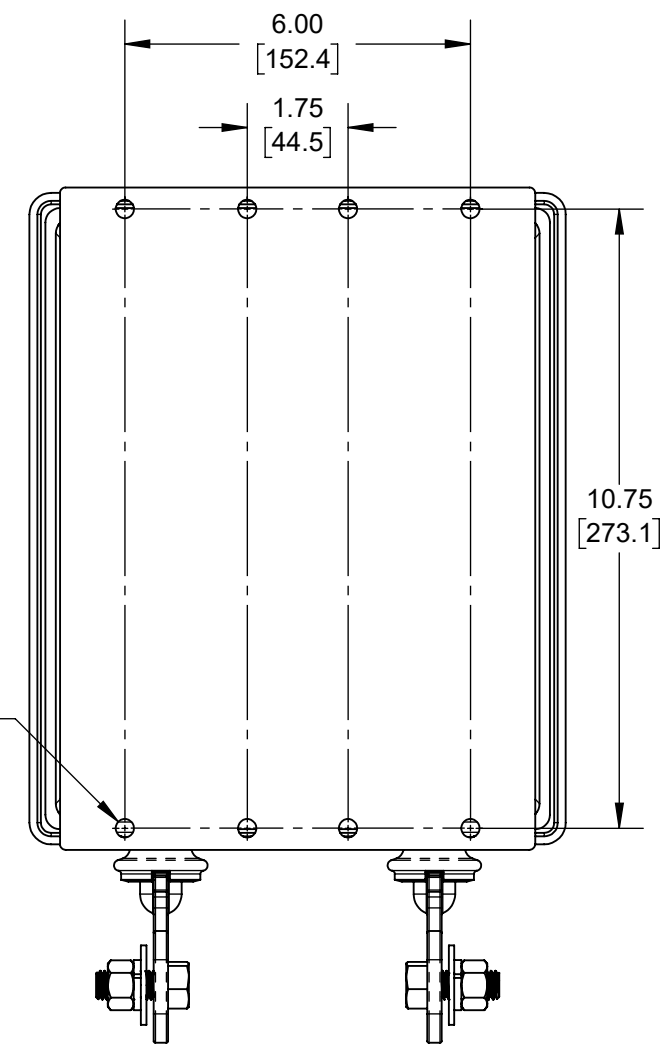
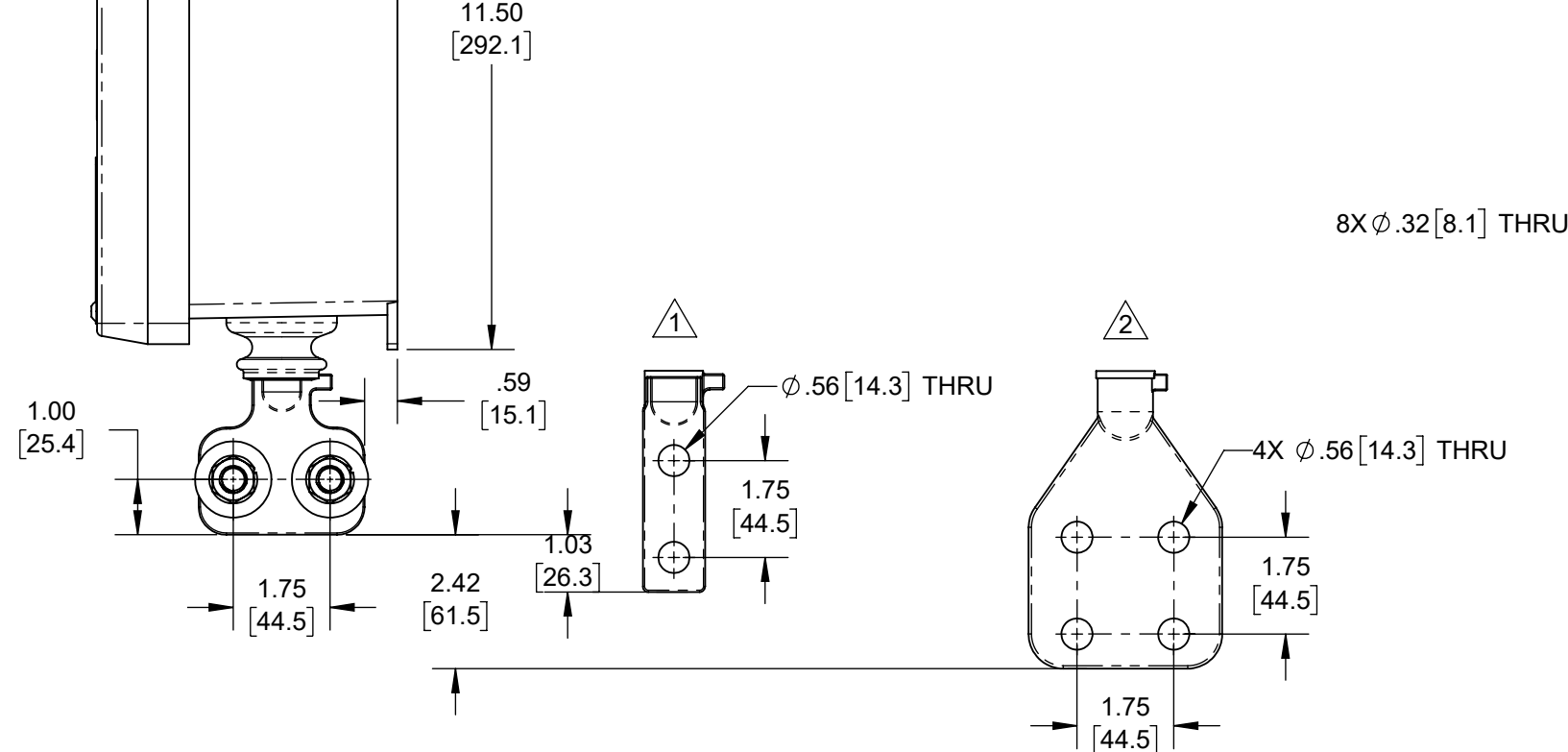
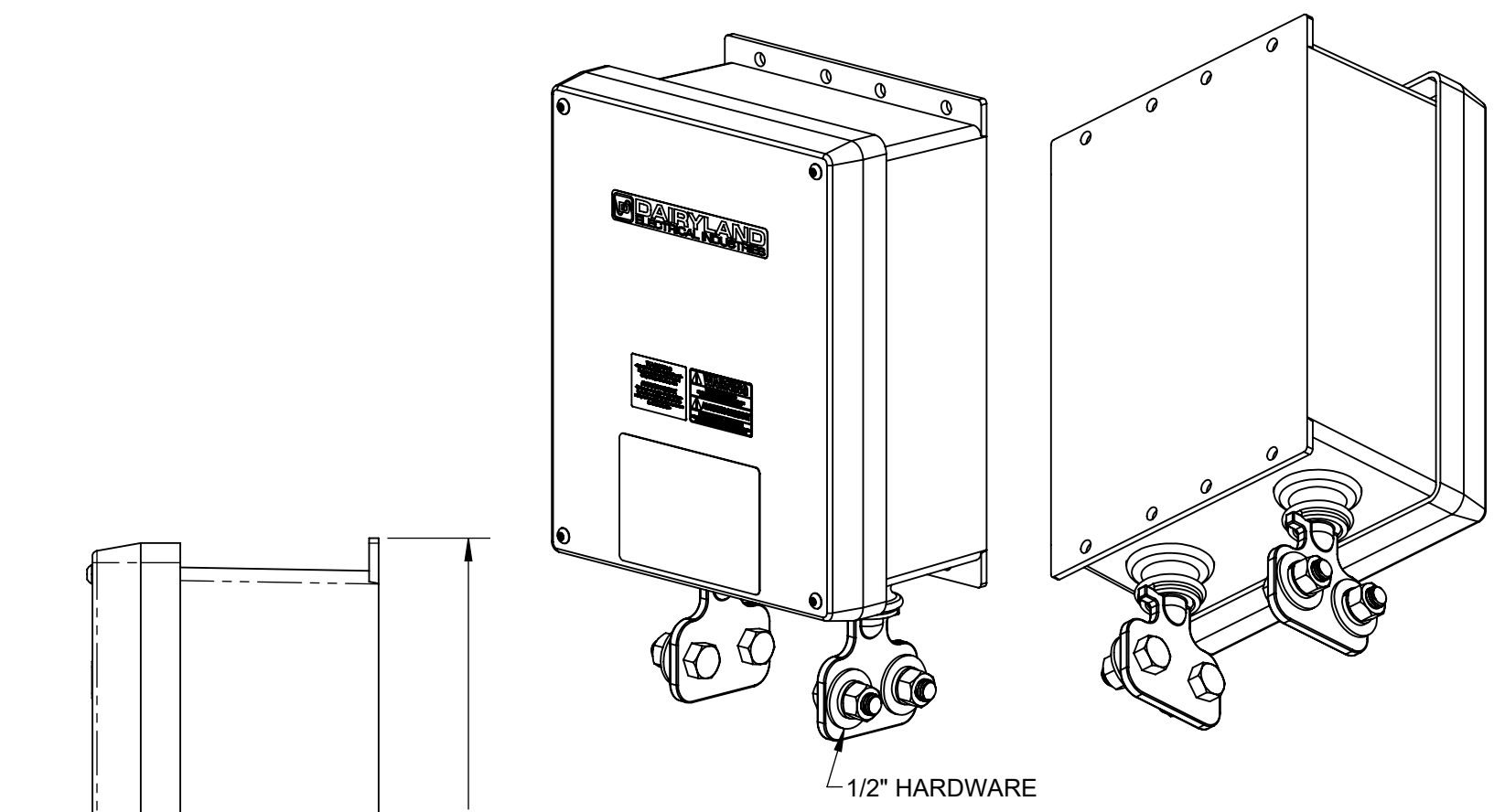
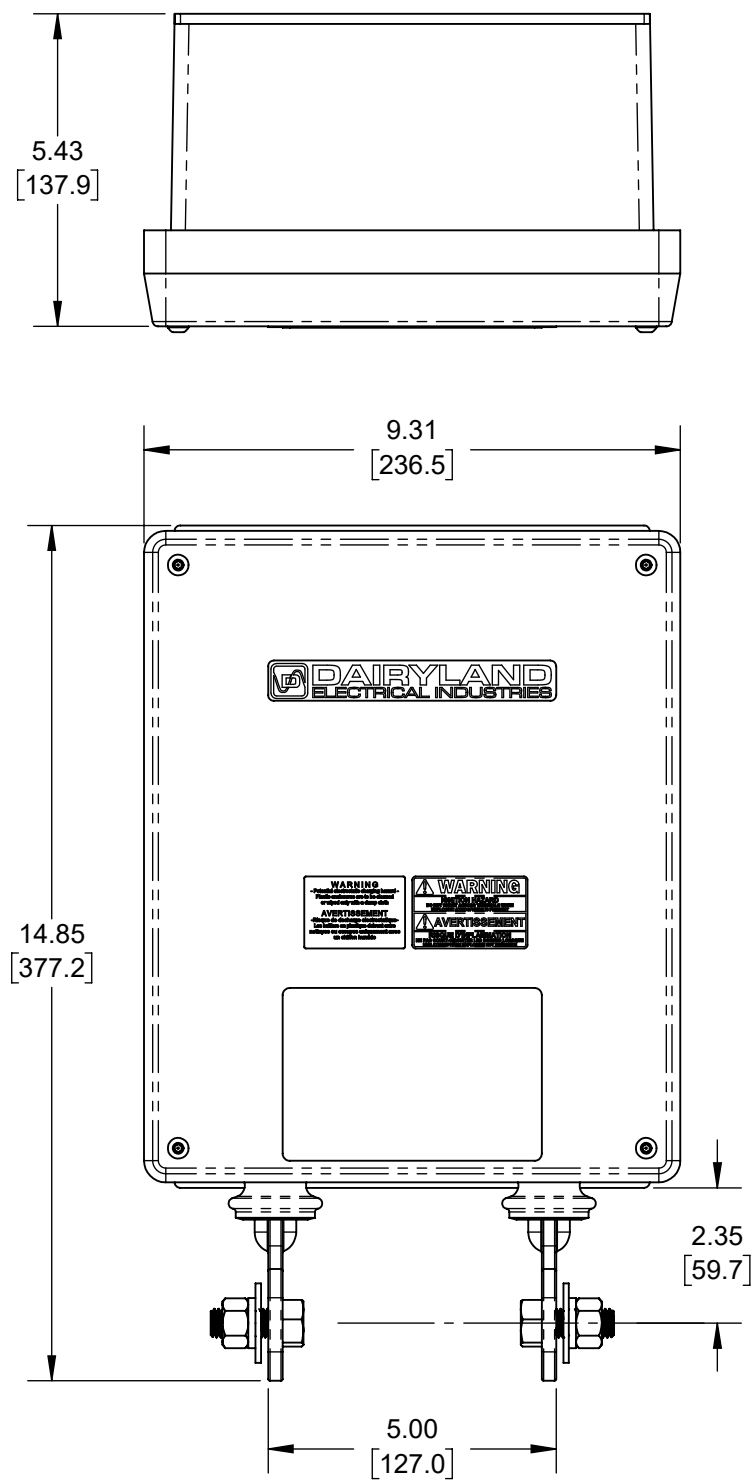
THE INFORMATION CONTAINED IN THIS DRAWING IS THE SOLE PROPERTY OF DAIRYLAND ELECTRICAL INDUSTRIES, INC. ANY REPRODUCTION IN PART OR WHOLE, WITHOUT THE WRITTEN PERMISSION OF DAIRYLAND ELECTRICAL INDUSTRIES, INC. IS PROHIBITED.



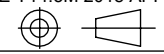

NOTES:
 1 ALTERNATE TERMINAL: SPECIFIED BY ADDING "-CC" TO ANY PCR MODEL NUMBER
 2 ALTERNATE TERMINAL: SPECIFIED BY ADDING "-4H" TO ANY PCR MODEL NUMBER

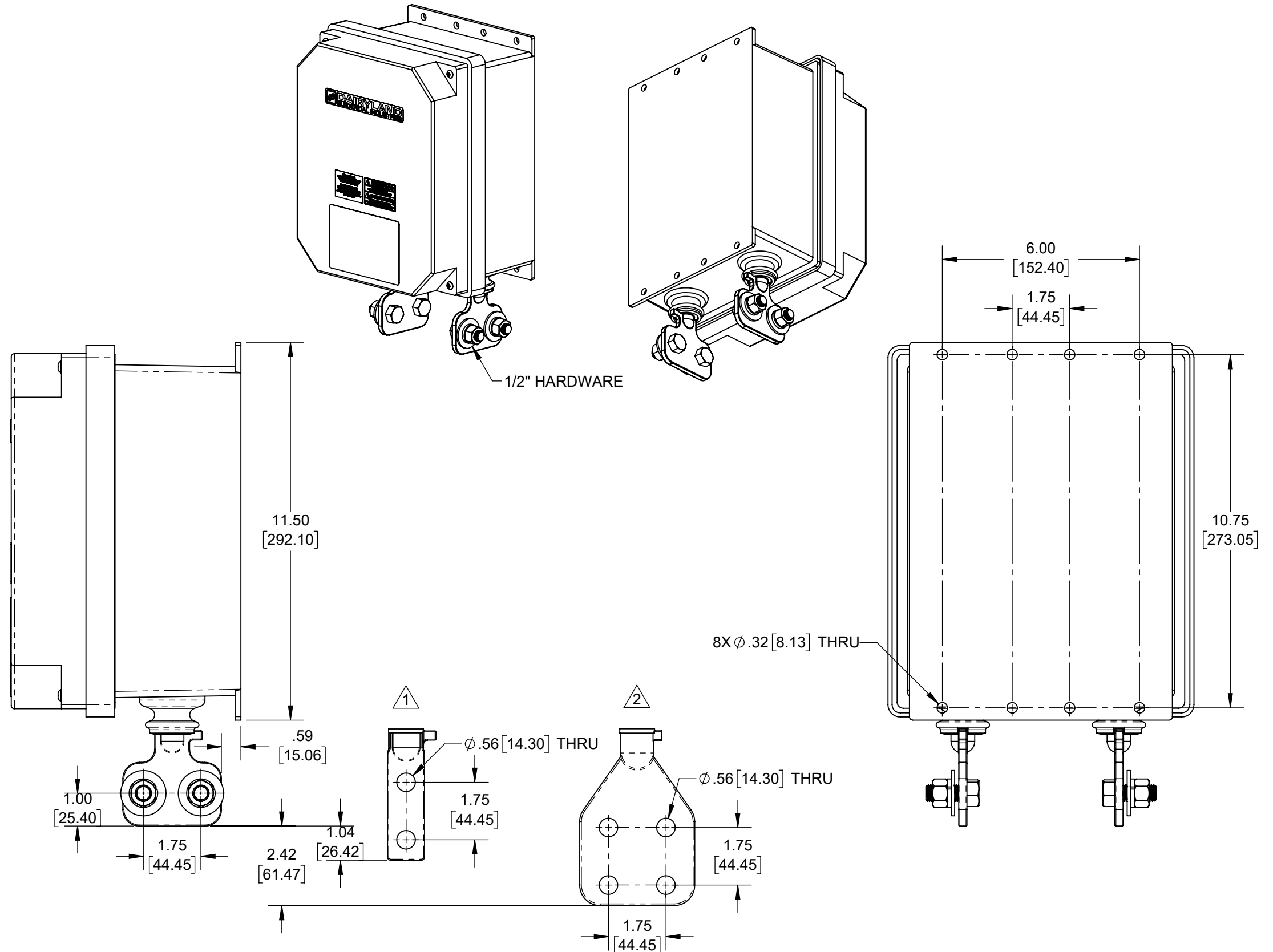
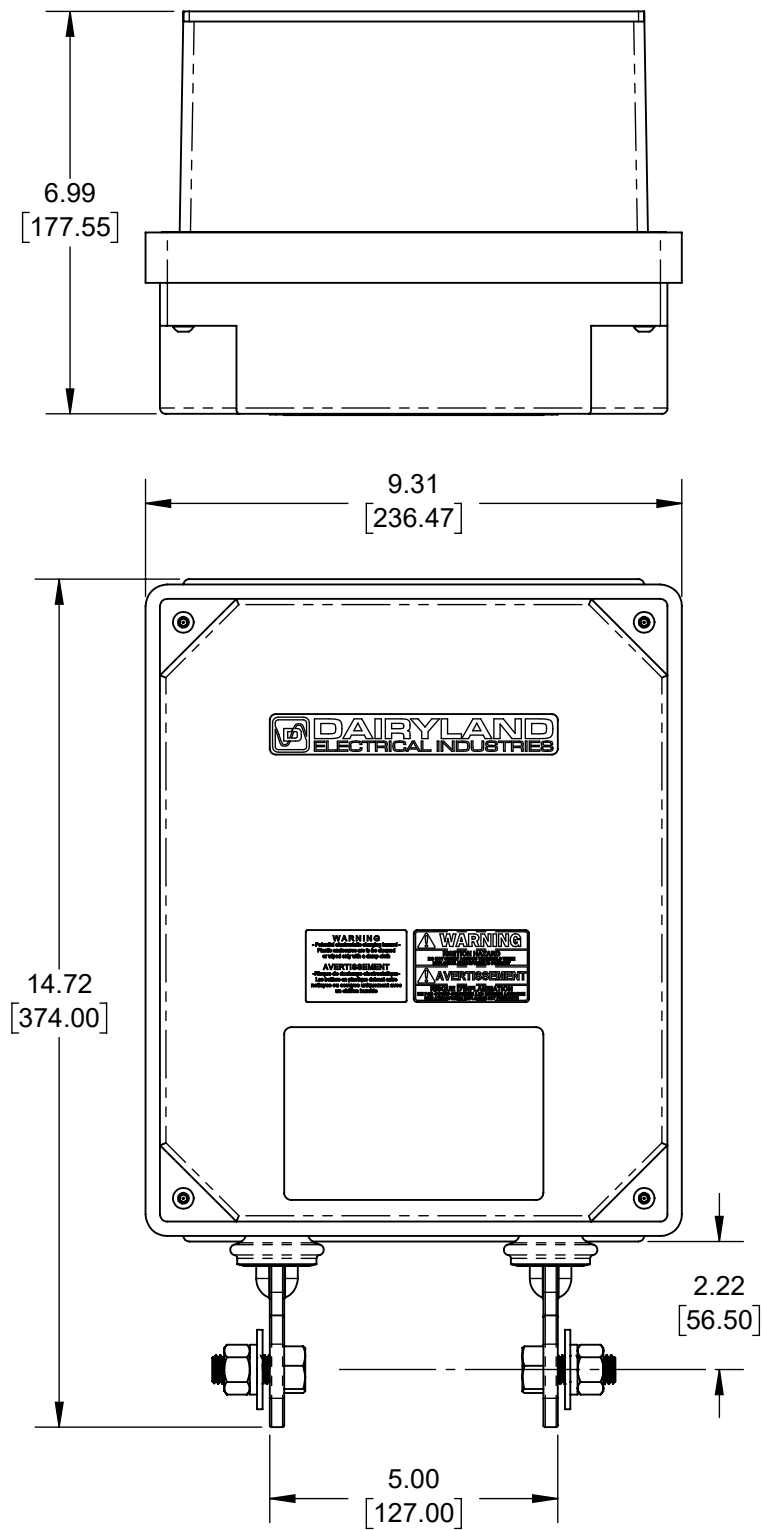
ASME Y14.5M 2018 APPLIES 	MATERIAL: NA	DRAWN: JPW	DATE DRAWN: 2015-08-17	 DAIRYLAND ELECTRICAL INDUSTRIES, INC. P.O. BOX 187 STOUGHTON, WI 53589 608-877-9900 DAIRYLAND.COM
UNLESS OTHERWISE SPECIFIED DIMENSIONS ARE IN INCHES. COMPUTER-GENERATED DRAWING DO NOT EDIT MANUALLY.	FINISH: NA	DWG APPROVAL: JSJ	DATE APPROVAL: 07/15/2025	
.XXX = ±.005" .XX = ±.01" .X = ±.03" ANGLES = ±1°		TITLE: PCR - 15kA OUTLINE DRAWING		
THE INFORMATION CONTAINED IN THIS DRAWING IS THE SOLE PROPERTY OF DAIRYLAND ELECTRICAL INDUSTRIES, INC. ANY REPRODUCTION IN PART OR WHOLE, WITHOUT THE WRITTEN PERMISSION OF DAIRYLAND ELECTRICAL INDUSTRIES, INC. IS PROHIBITED.	SHEET: 1 OF 1	DWG SIZE: B	SCALE: 3:10	REV: C PART #: 100085

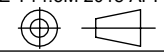

NOTES:

- ① ALTERNATE TERMINAL: SPECIFIED BY ADDING "-CC" TO ANY PCR MODEL NUMBER
- ② ALTERNATE TERMINAL: SPECIFIED BY ADDING "-4H" TO ANY PCR MODEL NUMBER

ASME Y14.5M 2018 APPLIES  UNLESS OTHERWISE SPECIFIED DIMENSIONS ARE IN INCHES. COMPUTER-GENERATED DRAWING DO NOT EDIT MANUALLY.	MATERIAL:	DRAWN: JPW	DATE DRAWN: 2015-08-17	 DAIRYLAND ELECTRICAL INDUSTRIES, INC. P.O. BOX 187 STOUGHTON, WI 53589 608-877-9900 DAIRYLAND.COM
	FINISH: NA	DWG APPROVAL: JSJ	DATE APPROVAL: 07/15/2025	
.XXX = ±.005" .XX = ±.01" .X = ±.03" ANGLES = ±1°	TITLE: PCR - 15kA/80A OUTLINE DRAWING		SHEET: OF 1 1	DWG SIZE: SCALE: REV: PART #: B 3:10 C 100087
THE INFORMATION CONTAINED IN THIS DRAWING IS THE SOLE PROPERTY OF DAIRYLAND ELECTRICAL INDUSTRIES, INC. ANY REPRODUCTION IN PART OR WHOLE, WITHOUT THE WRITTEN PERMISSION OF DAIRYLAND ELECTRICAL INDUSTRIES, INC. IS PROHIBITED.				